

- > **2/2, 3/2 NC/NO; Cartridge mounting**
- > **Very compact design (ø 8 x 19 mm)**
- > **Low power consumption (0,5 W)**
- > **Long life up to 100 million cycles**
- > **High flow to size ratio**



### Technical features

#### Medium:

Air, oxygen, neutral gases (10 % ... 95 % humidity, non condensing), 40 µm filtered

#### Operation:

Direct acting 2-way and 3-way valves

Normally closed and normally opened

#### Operating pressure:

0 ... 8 bar (0 ... 116 psi)

#### Mounting:

Cartridge

#### Size:

8 mm

#### Orifice:

0,5 ... 1 mm

#### Response time:

5 ... 10 ms

Response time measured according to ISO 12238

#### Life expectancy:

≥100 Mio. cycles

#### Mounting instruction:

The valve must be assembled in its housing with a lubricant that is compatible with the seals.

Max axial force supported by the valve: 75 (N).

#### Ambient/media temperature:

-10 ... +50 °C (+14 ... +122°F)

Air supply must be dry enough to avoid ice formation at temperatures below +2 °C (+35°F).

#### Materials:

Body: PPS

Seat seals: HNBR

Internal parts: stainless steel

### Electrical details

<b>Voltage:</b>	24 V d.c.
<b>Rating:</b>	100 % E.D.
<b>Voltage tolerance</b>	± 10%
<b>Power consumption:</b>	0,5 W
<b>Electrical insulation</b>	500 V a.c.
<b>Insulation class</b>	F (155°C)

### Following options on request

kv
Operating pressure
Medium temperature
Ambient temperature
Power consumption
Body
Seal
Electric connection
Voltage (3, 5, 6 or 12 V d.c.)
Degreased for oxygen use

### Pulse width modulation (PWM) control

A PWM can be used to control the valve and should be set as follows:

	Definition	Value to be applied
Hit voltage	Voltage used for the valve to commute	Valve nominal voltage
Holding voltage	Voltage applied to the valve after commutation	Set duty cycle to guarantee specified holding voltage. 50% of nominal voltage can be used if no value specified.
Hit time	Maximum time required to ensure full valve commutation	40 ms at T > 20 °C *1)
PWM frequency		20 ... 30 kHz



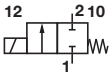
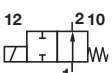
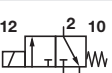
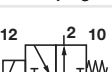

\*1) Please contact us for application outside of those conditions.

**Technical data - standard models - 24 V d.c.**

Symbol	Operation	Function	Orifice	kv factor *1)	Operating pressure (bar)		Seal Material	Drawing No.	Model
	2/2	NC	0,5	0,11	0 ... 8	0 ... 116	HNBR	1	14-211CA00-HH++AYJ
			0,8	0,2	0 ... 5	0 ... 72	HNBR	1	14-211CA01-HH++AYJ
			1	0,3	0 ... 1,5	0 ... 21	HNBR	1	14-211CA010HH++AYJ
	2/2	NO	0,6	0,11	0 ... 8	0 ... 116	HNBR	2	14-221CA060HH++AYJ
			0,7	0,2	0 ... 5	0 ... 72	HNBR	2	14-221CA070HH++AYJ
	3/2	NC	0,5	0,11	0 ... 8	0 ... 116	HNBR	3	14-311CA00-HH++AYJ
			0,8	0,22	0 ... 3	0 ... 43	HNBR	3	14-311CA01-HH++AYJ
			1	0,3	0 ... 0,5	0 ... 7	HNBR	3	14-311CA010HH++AYJ
	3/2	NO	0,6	0,12	0 ... 4	0 ... 58	HNBR	4	14-321CA060HH++AYJ

\*1) Cv = 0,07 kv

**Accessories**

<p>Test manifold with M3 ports, 1 position</p>  <p>Page 4 S141.0387 *1)</p>	<p>Test manifold with M3 ports, multiple channels up to 10 positions</p>  <p>Page 4 Available on request</p>	<p>Barbs mounting interface for Ø 2,5 mm ID tubing (up to 1 bar)</p>  <p>Page 4 S140.0226</p>	<p>300 mm flying leads mounted with 4 mm (or 2 x 2 mm) pitch SIL socket housing (Harwin M22-3010300)</p>  <p>S141.0466</p>
--	--	--	--

\*1) Two valve mounting screws are in scope of delivery

**Dimensions**

 Dimensions shown in mm  
 Projection/First angle

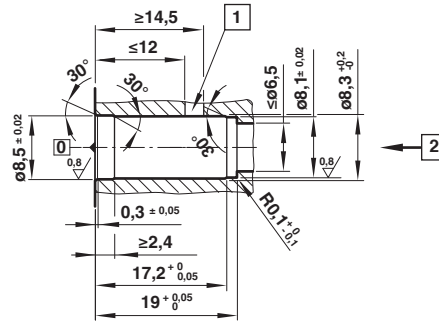
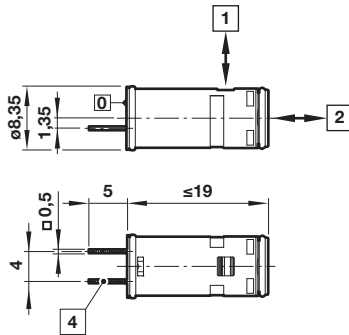
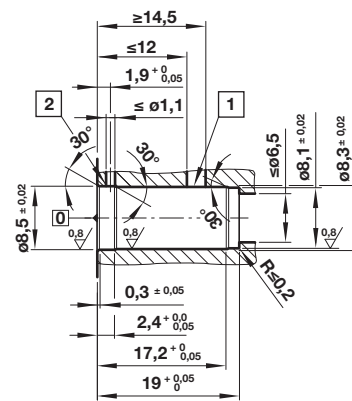
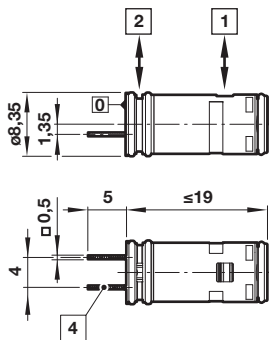
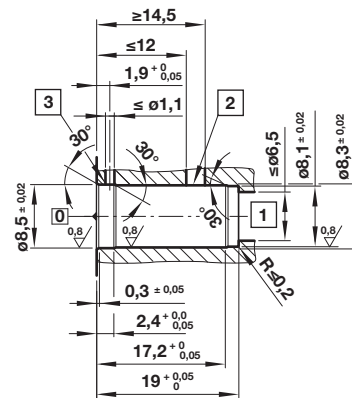
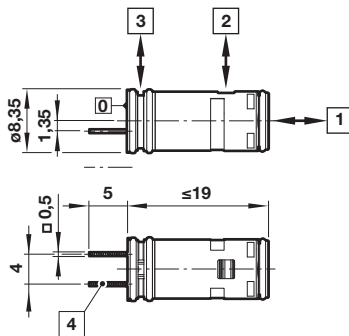
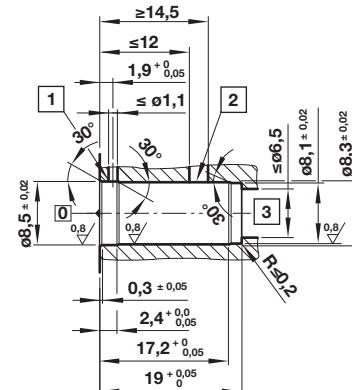
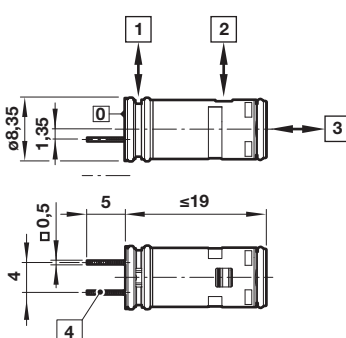
**1 CHIPSOL 2/2 NC**

**2 CHIPSOL 2/2 NO**

**3 CHIPSOL 3/2 - NC**

**4 CHIPSOL 3/2 - NO**

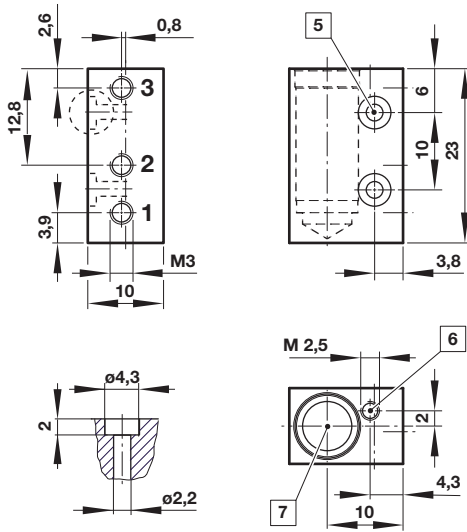
-  Faces to be aligned by retaining means
-  Inlet port
-  Outlet port
-  Exhaust port
-  Do not weld

**Dimensions**

**Test manifold, 1 position**  
(Aluminium)



**Barbs mounting interface**  
(Plastic, maximum operating pressure 1 bar)

Dimensions shown in mm  
Projection/First angle

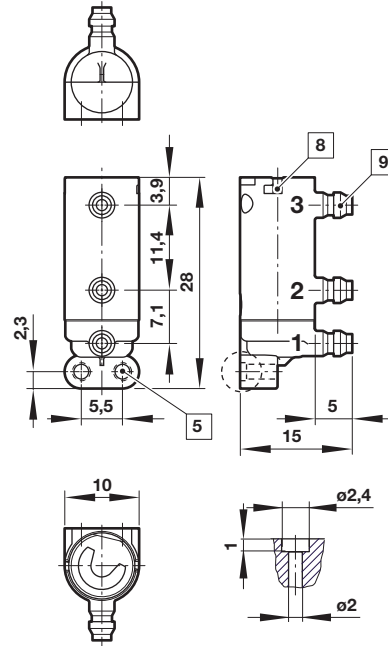

**Test manifold, up to 10 positions**  
(Brass)

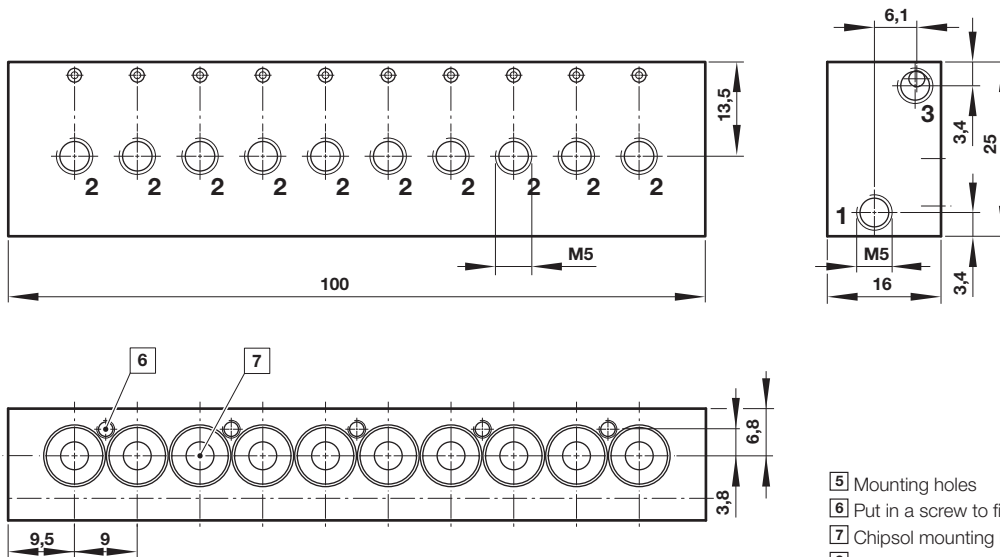

- 5] Mounting holes
- 6] Put in a screw to fix valve position
- 7] Chipsol mounting hole
- 8] Clip cover closed CHIPSOL mounting hole
- 9] Tubing ID 2,5 mm

**Warning**

These products are intended for use in air, oxygen and neutral gas systems only. Do not use these products where pressures and temperatures can exceed those listed under »**Technical features**«.

Before using these products with fluids other than those specified, for non-industrial applications, life-support systems, or other applications not within published specifications, consult FAS.

Through misuse, age, or malfunction, components used in fluid power systems can fail in various modes.

The system designer is warned to consider the failure modes of all component parts used in fluid power systems and to provide adequate safeguards to prevent personal injury or damage to equipment in the event of such failure.

System designers must provide a warning to end users in the system instructional manual if protection against a failure mode cannot be adequately provided.